REQUEST FOR QUALIFICATIONS
INEZ NASH PARK Public Art Project: Toledo, OH



I. PROJECT INTENT

The Arts Commission of Greater Toledo's Art in Public Places Program has partnered with the City of Toledo's Parks Department to commission a new work of public art integrated into Inez Nash Park.

Renovations to the park will include a quarter mile walkway, shelter, main event plaza, and a system of pathways and plazas that ultimately serve to connect several areas designed to encourage a variety of play, including the site of this public art project: a shoot-around court with five hoops designed for freeform play. The court measures approximately 50'-0" x 29'-9". The court painting process shall follow best practices as detailed in the Bloomberg Asphalt Art Guide, found here: [Guide | Asphalt Art](#)

A Design Review Board (DRB) plans to select three artists/teams to propose complete designs for the surface of the court and each of the 5 backboards. Finalists will be paid a stipend of \$2000 to participate in the concept proposal

process, which will include touring Inez Nash Park and meeting the Design Review Board and community members prior to developing a proposal. We are looking for artists that have experience with integrating public art into park environments as well as incorporating community input in the creative process. Submitted qualifications will be judged on a competitive basis.

The artist / team selected for the commission shall collaborate closely with the project management team through in-person meetings and other necessary means of communication when developing conceptual designs for artwork, including site integration, content, media, and application.

A map of the site can be viewed [here](#).

II. BUDGET

Three finalists will be paid \$2000 to develop proposals for the site.

Up to \$1000 will be reimbursable for expenses related to site visits, including travel, lodging and food.

The overall budget for commissioning, designing, and creating the artwork is \$60,500, including but not limited to expenses related to project completion, site preparation, additional design fees, materials, equipment, documentation, transportation, installation and travel.

III. ELIGIBILITY

The project is open to all artists in the United States of America, age 18 and over, regardless of race, color, religion, national origin, gender, age, military status, sexual orientation, marital status, or physical or mental disability. Artist teams are eligible to apply, including teams of artists from multiple disciplines.

IV. TIMELINE

August 21, 2024	Request for Qualifications (RFQ) Launch
September 24, 2024	Deadline for RFQ Submissions
September 25, 2024	Review of Applications Starts
October 17, 2024	Finalists Notified
October 29, 2024	Finalists Site Visits
December 3, 2024	Finalists Present Proposals
December 17, 2024	Winning Proposals Announced
2025	Installation

The Arts Commission reserves the right to change the project timeline. Dates for site visits are tentative and will be based on the availability of the finalists.

V. HOW TO APPLY

Artists interested in this project must prepare and submit the following:

- Letter of Interest - This letter should be no more than one page and should explain the artist's interest in the project.
- Current Resume - If submitting as a team, a current resume for each team member should be provided.
- Visual Support Materials - Submit 5 digital images of your most recent professional work.
- Annotated image list - The image list must include the artist's name and a brief description of image stating its title, date, medium, size, location and if a commissioned project, the commission budget.
- References - A list of at least three professional references that have an intimate knowledge of their work and working methods. The list must include complete emails and telephone numbers.

All submissions must be received by 11:59 pm EST, September 24, 2024.

Materials must be submitted at the link below:

[Inez Nash Request For Qualifications](#)

VI. SELECTION PROCESS

The Design Review Board for this project will review all submissions and select up to three artists/teams as finalists. The finalists will then be asked to develop a conceptual approach for artwork at the site and make a presentation of their proposal, including concept, materials, details of maintenance guidelines, special equipment needs, and budget. The finalists will be compensated \$2000 dollars (\$2000) for their participation in this stage of the selection.

The Design Review Board will be composed of members of The Arts Commission, City of Toledo Parks Department staff, residents, and additional stakeholders.

VII. ABOUT TOLEDO

Toledo is located on the western shore of Lake Erie and is the fourth largest city in Ohio, with a population of approximately 650,000 people in the metropolitan area. Toledo has a storied past in the manufacturing of many well-known icons of industry including The Jeep and Toledo Scale. Toledo is also known as The Glass Capital of the World for glass manufacturing and is the birthplace of the American Studio Glass Movement.

Toledo has an impressive collection of public art, with large-scale sculptures, murals, and functional structures by noted artists from all over the world. Many of these pieces were acquired through the pioneering 1977 ordinance that set aside one percent of Toledo's Capital Improvement Budget for the purchase, conservation, and public education of art. The city also offers a wide array of cultural opportunities including The Toledo Museum of Art, The Toledo Symphony Orchestra and The Toledo Opera.

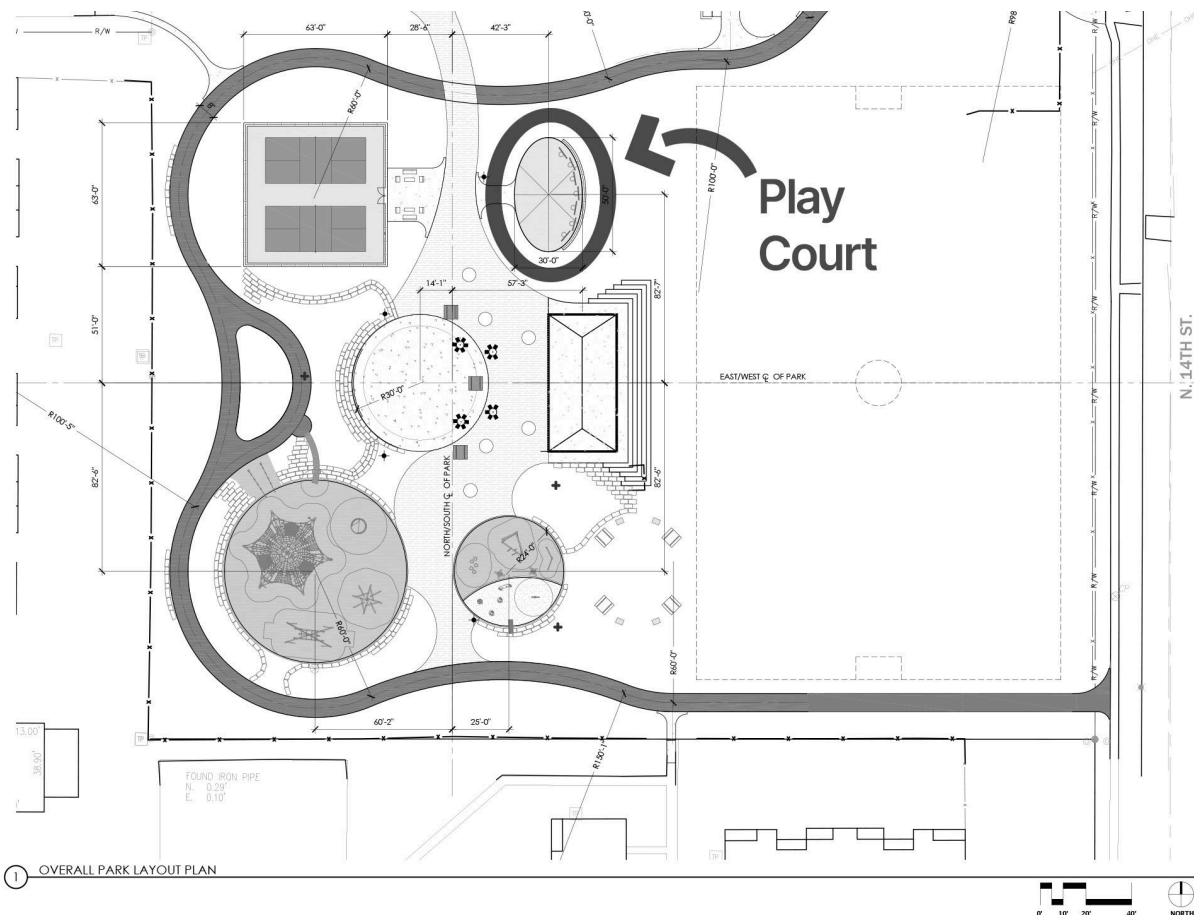

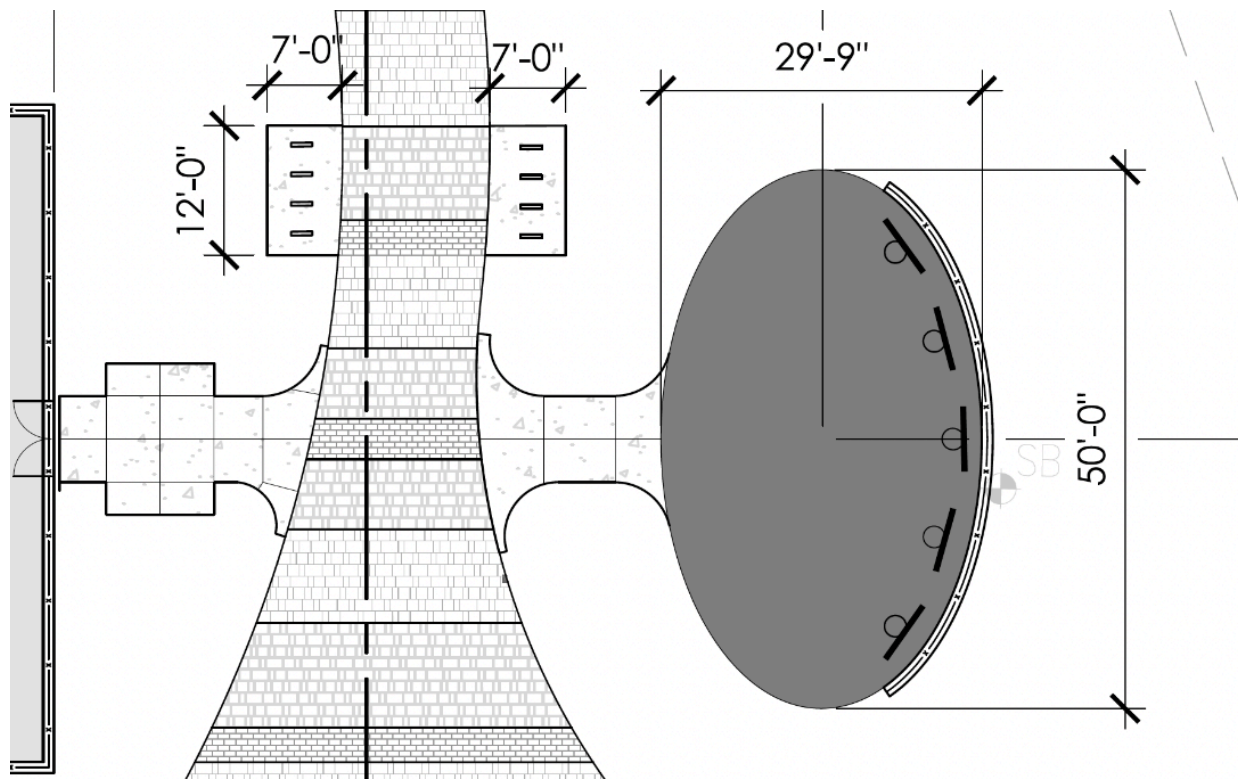

For further information, please contact: Nathan Mattimoe, Director of Art in Public Places; 419-254-2787 ext. 1011.

About The Arts Commission

The Arts Commission is the longest standing arts commission in the state of Ohio, founded in 1959, administering the City of Toledo's One Percent for Art Program since 1977. The Arts Commission is supported in part by the Ohio Arts Council and The National Endowment For The Arts.

Inclusion, Diversity, Equity, and Access Statement

Inclusion, diversity, equity and access are fundamentally important to our work at The Arts Commission. Our aim is to provide access and opportunity to art and culture for all in our community. It is our committed practice to stand alongside, listen and act based upon community needs. We have a responsibility to advocate for inclusion, diversity, equity and access. The Arts Commission will continue to deepen this practice as we move into the future.

The Arts Commission believes that the arts can provide the space to foster conversations that bring us together. The arts have long stood in the gap as a bridge between cultures. They have served as a place to support healing, as well as a place to develop and exchange compassion. We trust the arts in this role. By embracing our differences and celebrating our similarities we build a more vibrant, just, and inclusive society.